

FRÍANT

**ALL
WORKSTYLES
WELCOME**

VERITY





Verity captures the modern workplace — connecting with others while maintaining the valuable balance of privacy and openness.

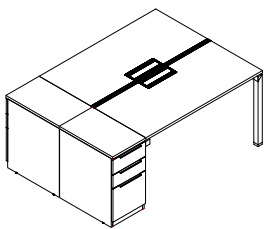

Stand-Alone Units

Save time with Verity Stand-Alone units, which are pre-configured stations — just add accessories and storage.

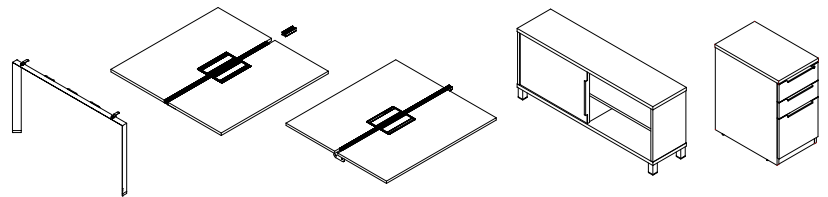

Elements, for building your own

For full customization choose Verity Elements, allowing selection of each support, surface and more including storage and accessories.

HOW DO YOU BENCH

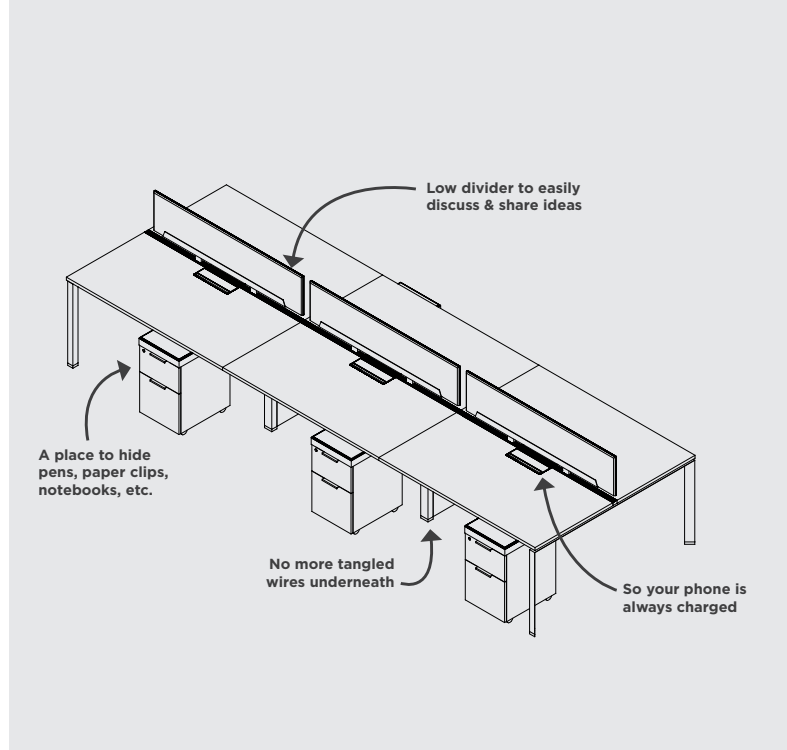

Verity creates workspaces that welcome interactions, enhancing the workflow for teams. It's easy to share at the bench, minimizing the need to relocate for meetings.

A well-balanced open office environment also recognizes the individual's needs, particularly the element of privacy. Create visual privacy with screens available in fabric, glass and markerboard or add in space-dividing storage.

As teams grow and change, Verity can be reconfigured or expand to support new dynamics. Create a happy and productive workspace with Verity benching.

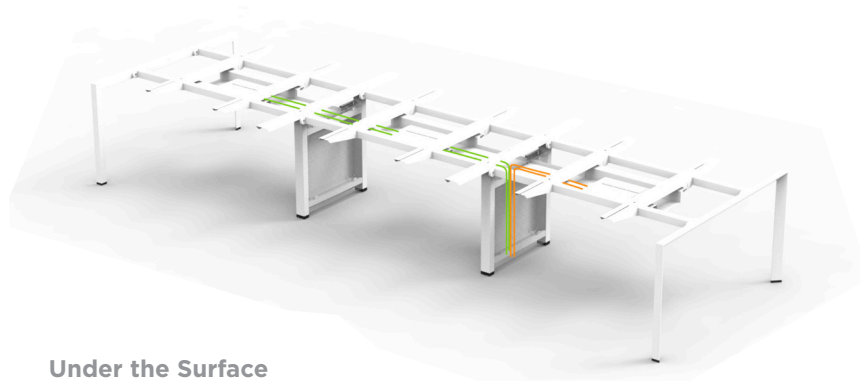

Under the Surface

Everyone loves a wire-free workspace. Stay connected by running power and data discreetly under the surface for full connectivity and a seamless look.



DETAILS



Build-in privacy with fabric, glass or markerboard screens.



Modular desk accessories, track-mounted or surface-mounted



Power/Data distribution trough organize wires away from view.



Storage elements divide space and provide additional privacy.

MATERIALS

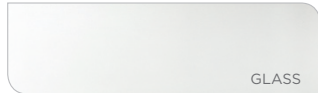

PAINT



WORKSURFACES



FEATURES & BENEFITS

- Order pre-configured Stand Alone units or build your own Elements
- Build single-sided or double-sided benching units
- Powered/non-powered benching
- Add on privacy elements as needed with fabric tackboards, glass screens, markerboard and modesty panels
- Select worksurface support options including legs, pedestals, cabinets, or credenzas
- New laminate finish, Light Walnut
- Limited Lifetime Warranty to the original owner

GENERAL DIMENSIONS

Single-Sided Units

D: 25.5", 31.5"

W: 48", 54", 60", 66", 72", 78", 84", 96"

Double-Sided Units

D: 49.5", 61.5"

W: 48", 54", 60", 66", 72", 78", 84", 96"

TYPICALS

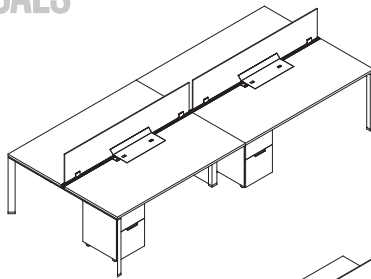

4 PACK BENCHING

- Clear glass screens
- Metal shelf
- Box/File mobile pedestals
- Power/data distribution trough

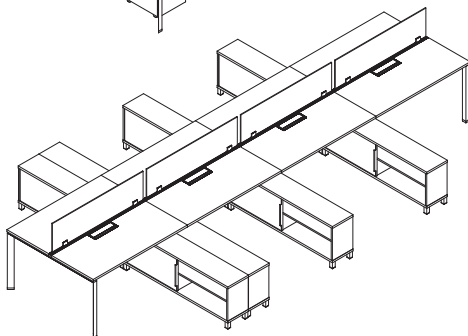

8 PACK BENCHING

- Clear glass screens
- Storage credenzas
- Power/data distribution trough

ELECTRICAL/TECHNICAL

- Powered units include 8-wire, 4 20-amp circuits
- Easy access to power/data through the access grommet
- High cable lay-in capability allowing cables to run under the surface and through center support legs

ENVIRONMENT

- Up to 45% recycled content (30% pre-consumer plus 15% post-consumer) in a typical configuration
- Up to 75% recyclable at the end of its useful life
- May contribute to LEED points